

SceneControl™ 10 Motion Control System

SceneControl 10 console provides programming for an unlimited number of cues, whether the production requires complex cues with many moving battens or synchronized groups of point hoists. The 10.1" graphic touch-screen display shows the operator the position of each batten and all of the targets, so you're never in the dark about elements in motion.

Applications

Medium to small venues with general performances such as: Theaters, Concert and Opera Houses, Colleges and Universities, High Schools, Middle Schools, Houses of Worship

Features

- Unlimited programming of shows
- Unlimited numbers of cues per show
- Up to 24 channels (axes)
- External USB ports for copying files or connecting approved input devices
- Multiple consoles can be networked together (requires network storage device)
- Motion commands initiated and maintained by hard-wired, illuminated push buttons that are not part of any touch screen function
- Start/Stop on axis multiple times within a cue or send an axis to multiple targets
- Run more than one cue at a time
- Run repetitive motion loops
- Change the speed of an axis in motion
- Create motion profiles based on time or velocity
- User ID and passwords which give the ability to restrict functions to appropriate users
- Multi-language supporting English plus two additional languages. Accepts input of Western, Russian, Asian and Arabic characters
- Data can be presented in units of feet/inches, decimal feet, meters or as a percentage
- Grouping with the ability to synchronize any number of hoists into a control group
- Create an unlimited set of macros for frequently used functions
- System critical actions are recorded and automatically saved in a time-stamped file
- Available as a rack mount, wall mount and a pendant



Options

- SIL3 Emergency Stop Upgrade
- Load Sensing
- Server or Network Storage Space (NAS)
- Remote access to a service technician via a secure access device

Specifications

- Unlimited programming of shows
- Up to 24 channels (axes)
- Multilingual interface
- Illuminated software function macros keys
- Unlimited numbers of cues per show
- Synchronized group operation
- Illuminated STOP/GO buttons

Safety

- Emergency Stop Operator
- Safety constraint algorithms
- Status/Alarm page
- Hold-to-Run bar
- Multi-level security
- Event log

Networking and Processing

- Networks with other J.R. Clancy consoles
- 32G Hard drive free storage space

Monitors and Screens

- 10.1" Touch Screen

Continued on the following page.

Dimensions

- SC10R: 19" w x 6" d x 5RU h (482 mm x 152 mm x 5RU)
- SC10R+: 19" w x 6" d x 8RU h (482 mm x 152 mm x 8RU)
- SC10W: 20" w x 8" d x 16" h (508 mm x 203 mm x 406 mm)
- SC10W+: 20" w x 8" d x 16" h (508 mm x 208 mm x 406 mm)
- SC10P: 12.24" w x 2.95" d x 11.06" h [3.73"D w/ Estop operator] (311 mm x 75 mm x 281 mm [95 mm w/Estop operator])
- **Note:** 1 RU (Rack Unit) = 1.75" (45 mm)

System

- Operating System: MS Windows embedded
- Motion Control Software: Raynok for J.R. Clancy

Warranty and Support

Three-Year Warranty against defects in materials or workmanship is provided on all J.R. Clancy equipment. Our warranty is contingent on operation by trained personnel and an annual equipment inspection of a J.R. Clancy authorized technician.

24/7 factory technical support with additional service and assistance provided by a worldwide network of J.R. Clancy authorized dealers.

Inspection and maintenance are available through J.R. Clancy's T.I.M.® (Train, Inspect, Maintain) Program. For more information call 1-800-836-1885 or email service@jrclancy.com.

Additional Information

Additional information on J.R. Clancy systems is available at www.jrclancy.com.

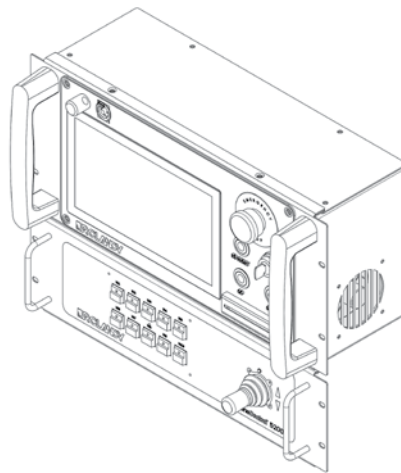
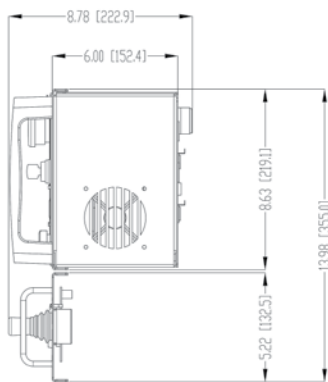

Order Information

Number	Description
064-SC10W	SceneControl 10W Wall Mount
064-SC10W+	SceneControl 10W Wall Mount with panel, macros, joystick
064-SC10R	SceneControl 10R Rack Mount
064-SC10R+	SceneControl 10R Rack Mount with panel, macros, joystick
064-SC10P	SceneControl 10P Hand-held Pendant



© 2018 Wenger Corporation
USA/2018-09/W



WENGER CORPORATION Phone 800.4WENGER (493-6437) Worldwide +1.507.455.4100 | Parts & Service 800.887.7145 | Canada Office 800.268.0148 | wengercorp.com
555 Park Drive, PO Box 448 | Owatonna MN 55060-0448

JR CLANCY Phone 800.836.1885 Worldwide +1.315.451.3440 | jrclancy.com | 7041 Interstate Island Road | Syracuse NY 13209-9713

GEARBOSS Phone 800.493.6437 | email gearboss@wengercorp.com | gearboss.com | 555 Park Drive, PO Box 448 | Owatonna MN 55060-0448